

# Comprehensive solutions for testing and analyzing the mechanical properties of fasteners

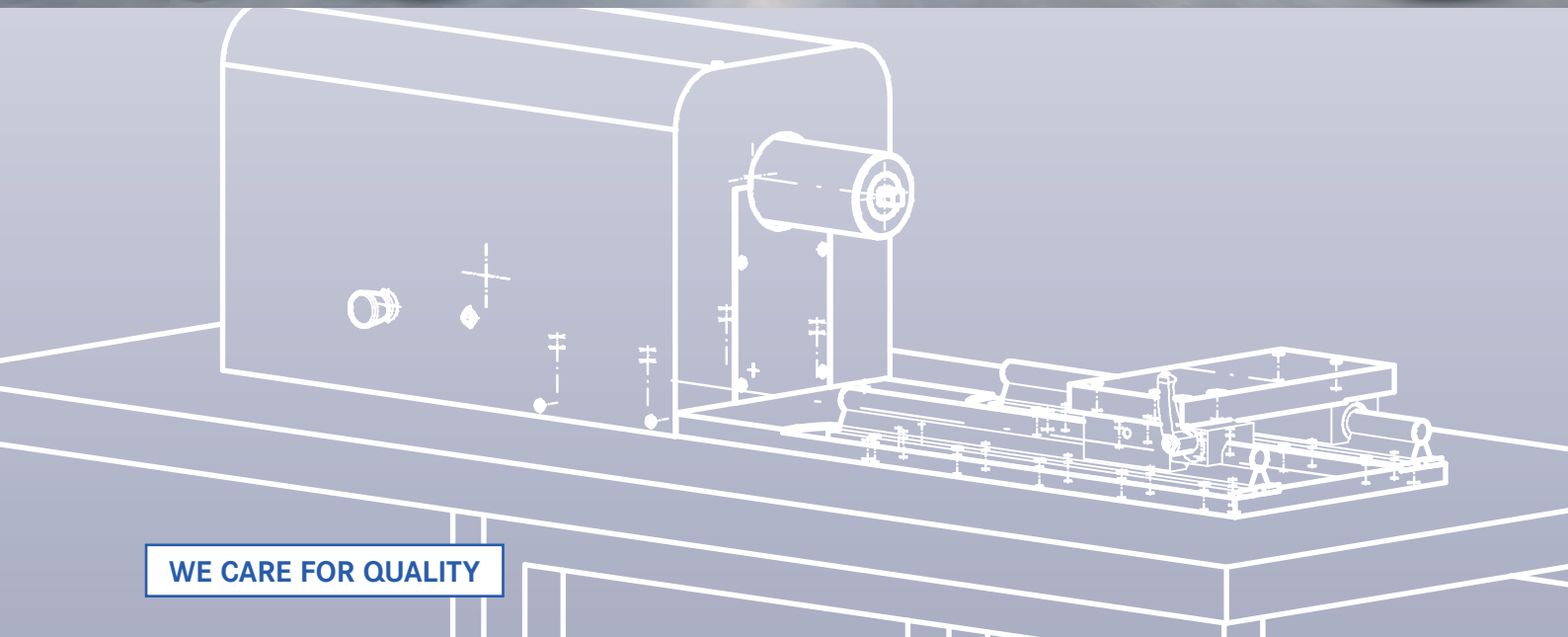

# Coefficient of friction testing machines

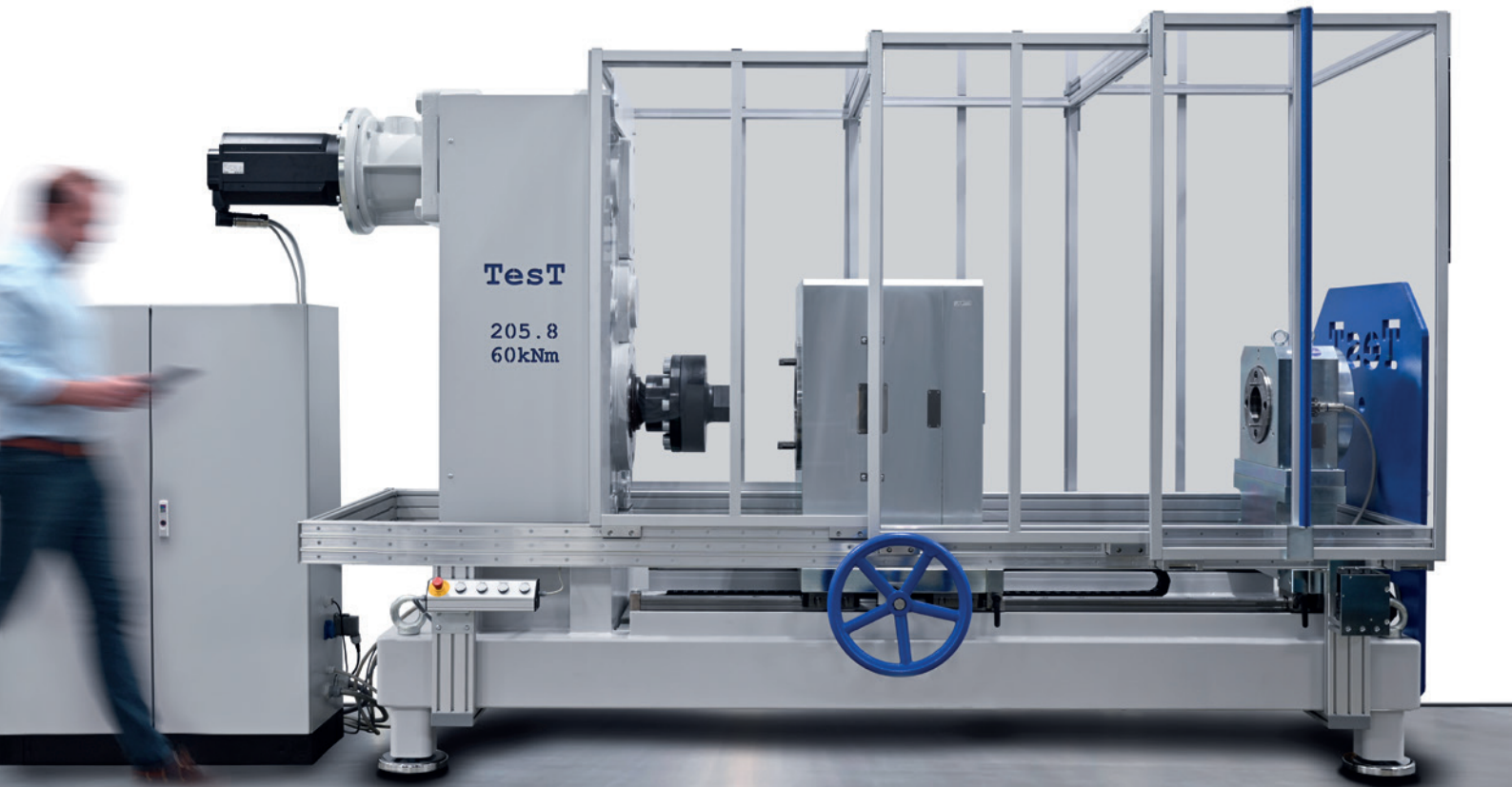

Preparation of a friction coefficient determination

## Quality is no coincidence

Test offers integrated solutions for testing of bolts, nuts, washers and locking elements, made in Germany.

Our coefficient of friction test benches, equipped with our patented multi-component sensors, have conquered the world. Our testing devices meet all national and international standards and can be adapted to any company's specific requirements. The measured and evaluated forces, torques and angles allow for the determination of friction coefficients for screws, bolts, nuts, and other components.

This information ensures that components can be used to achieve optimal and safe fastening.

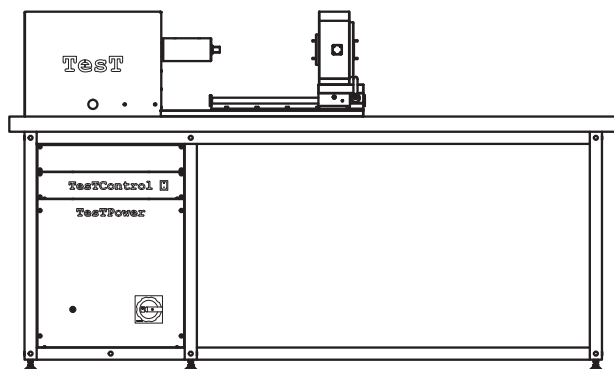

Model	Torque [Nm]	Speed [1/min]
205.1.30Nm	30	30
205.2.150Nm	150	30
205.3.250Nm	250	30
205.3.600Nm	600	30
205.4.1100Nm	1.100	30
205.4.2000Nm	2.000	30
205.4.3200Nm	3.200	15
205.5.4000Nm	4.000	15
205.5.7000Nm	7.000	10
205.5.10kNm	10.000	10
205.6.12kNm	12.000	10
205.6.18kNm	18.000	10
205.7.30kNm	30.000	8
205.7.40kNm	40.000	8
205.8.60kNm	60.000	4.5
205.8.80kNm	80.000	3

Other configurations available on request

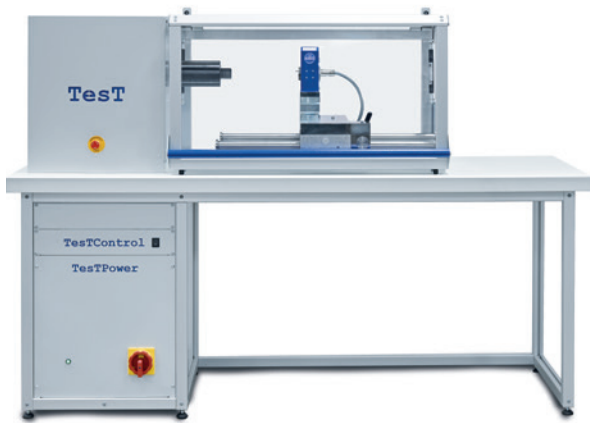

Friction coefficient test rig model 205.4 with 201.1

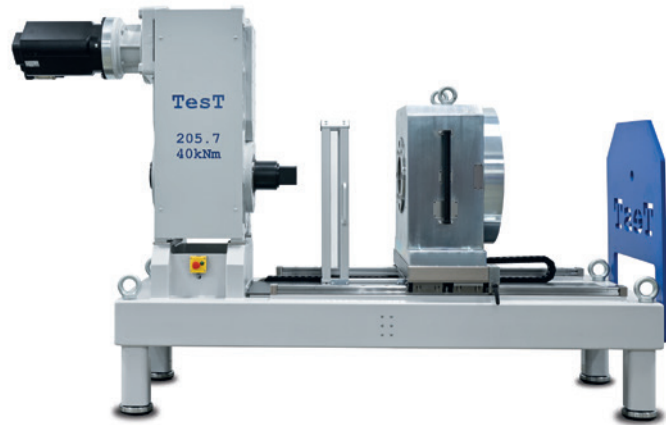

Friction coefficient test rig model 205.7 with 201.7

### Multi-component sensors

The patented multi-component sensors enable the effective decoupling of stresses within bolted joints resulting from clamping force and torque. This well-established measuring principle, which has been further developed over many years, enables precise measurement of the clamping force, the total torque and the partial torques within only one robust sensor. Additionally, the angle is measured within the machine with high resolution.

These innovations find primary applications in the automotive industry, screw, bolt and nut manufacturing, as well as in large-scale plant construction, power plant construction, and notably, wind power plant applications.



### Measuring range table of TestT sensors

Model	Force [kN]	Torque [Nm]
20x.1	25	30
20x.2	30	50
20x.2	50	100
20x.2	75	150
20x.3	100	250
20x.3	150	400
20x.3	200	600
20x.4	300	1.100
20x.4	500	2.000
20x.4	600	3.200
20x.5	700	4.000
20x.5	1.000	7.000
20x.5	1.300	10.000
20x.6	1.400	12.000
20x.6	1.800	18.000
20x.7	3.000	30.000
20x.7	3.500	40.000
20x.8	4.500	60.000
20x.8	5.500	80.000

Other configurations available on request

$$x=1 \dots T_{\text{tot}} + T_b$$

$$x=3 \dots T_{\text{tot}}$$

# Vibration testing machines for bolted joints

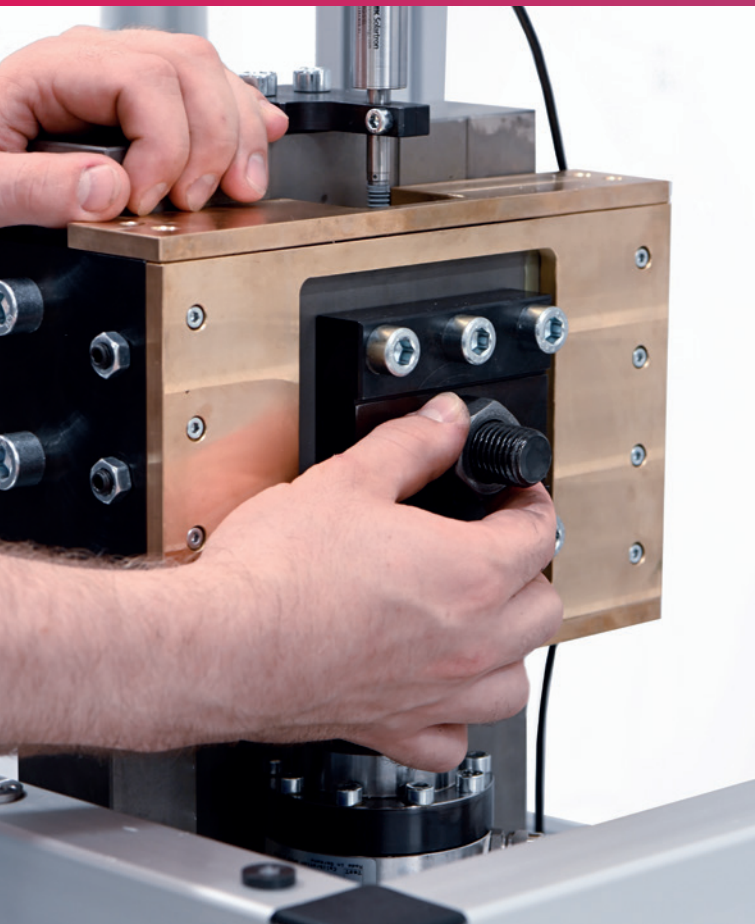

Installing a sample

## Junker vibration testing machines

The comprehensive quality inspection of screws, bolts, and nuts includes vibration testing, which is conducted on Junker vibration testing machines. These machines are utilized to dynamically assess the loosening properties of fasteners under transverse load.

The components to be tested are assembled into the machine's sensor up to a defined preload and then subjected to a dynamic transverse load at a constant or variable frequency.

## Flexibility in control and evaluation

The preload-time diagram determined in the process diagram, along with the number of cycles, provides corresponding information about the loosening behavior of the bolted joint under dynamic lateral load.

In conjunction with our **TestWinner® 950** software, our customers receive optimal efficiency and flexibility as well as a direct statement about the loosening angle, preload force, lateral force and lateral displacement amplitude. Optionally, the tightening torque can also be recorded at the start of the test.

Test Vibration testing machines from can be used to test bolted joints in accordance with DIN 65151, DIN 25201-4, ISO 16130, GB/T 10431, including the option of controlling the transverse displacement amplitude during the test.



Working area of a 208.200kN





Complete setup of a Test vibration testing machine

### Technical versions of the Test vibration testing machines

Model	208.50kN	208.200kN	208.300kN	208.600kN	208.1200kN
Max. bolt dimension	M12	M27	M33	M48	M64
Max. preload force	50 kN	200 kN	300 kN	600 kN	1200 kN
Max. lateral force	15 kN	63 kN	100 kN	200 kN	400 kN
Measurement of lateral force	No	Yes	Yes	Yes	Yes
Transverse displacement amplitude	$\pm 0 \dots 1.5$ mm	$\pm 0 \dots 2$ mm	$\pm 0 \dots 2$ mm	$\pm 0 \dots 2$ mm	$\pm 0 \dots 2$ mm
Control of lateral displacement amplitude during the test	No	Yes	Yes	Yes	Yes
Max. test frequency	15 Hz	15 Hz	15 Hz	15 Hz	12.5 Hz
Measurement of the release angle (option)	No	Yes	Yes	Yes	Yes
Motorized controlled tightening (option)	No	Yes	Yes	Yes	Yes

Other configurations available on request

# TestController 850

## TestWinner® 950

### Measurement and control electronics

At the heart of all Test testing machines lies the integration of **TestController 850** for measurement and control electronics, combined with the **TestWinner® 950** application software. This pairing creates a versatile and highly flexible system capable of managing everything from test requirements to generating detailed test reports.

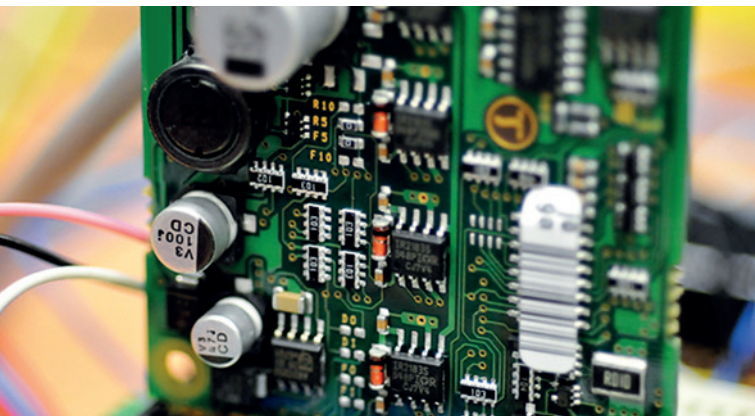

Test Controller

The **TestController 850** guarantees a rapid response to a wide range of test scenarios, thanks to its extremely fast internal control loop for executing programmed test sequences. Various analog and digital accesses to the control loop can be configured via modular interfaces.

In addition to the usual control value outputs for the drives for force application, high-resolution inputs are always defined for measured value acquisition. Inputs and outputs for a separate safety circuit are always pre-assigned.

A standardized USB 2.0 interface connects the electronic components with a standard Microsoft Windows PC. The control loop always remains independent and is therefore not affected by the priorities and runtimes of the operating system.

### The convenient testing software

**TestWinner® 950** enables the convenient management and combination of a wide variety of processes, their display and evaluation.

The **TestWinner® 950** software package is designed to be open and flexible, catering to a wide range of testing machine requirements. Test sequences and evaluation calculations can be freely programmed using macro commands. This flexibility applies to both customized program sequences and calculations for component testing, as well as standardized procedures and calculations for material testing.

If new tasks are added to the test, these can be converted into a corresponding sequence with the corresponding evaluation within a short time. The user himself has complete freedom to intervene in the test configuration. This can be restricted for individual user groups using the integrated rights management.



TestWinner® 950 testing software

# Calibration and maintenance



## Calibration service

The traceable calibration of testing machines and measuring devices is essential for industrial quality controls. Calibration certificates are a mandatory proof of test equipment monitoring for ISO 9001 and ISO 17025 standards.

Calibration intervals depend on the applicable standard, but generally should not exceed 12 months. Special considerations apply for changes of location or after repairs.

The first machine we developed over 25 years ago was a universal testing machine. This very first machine is still in operation thanks to regular calibrations and modernizations.

## Maintenance service

TesT is accredited by the Deutschen Akkreditierungsstelle (DAkkS) according to ISO/IEC 17025 for the on-site calibration of testing machines for the measurands force, length and torque (materials testing machines) and as a permanent testing laboratory for the calibration of compression load cells.

Accordingly, our calibration laboratory has the expertise, independence and performance required to ensure that our customers can rely on the data obtained with the testing system. We are authorized to calibrate testing machines and systems on-site and issue calibration certificates recognized worldwide

Take advantage of our many years of experience in the field of calibration.

## Advantages

- Reliable long-term service
- Know-how directly from the manufacturer
- Individual maintenance interval
- Helpful tips for machine users

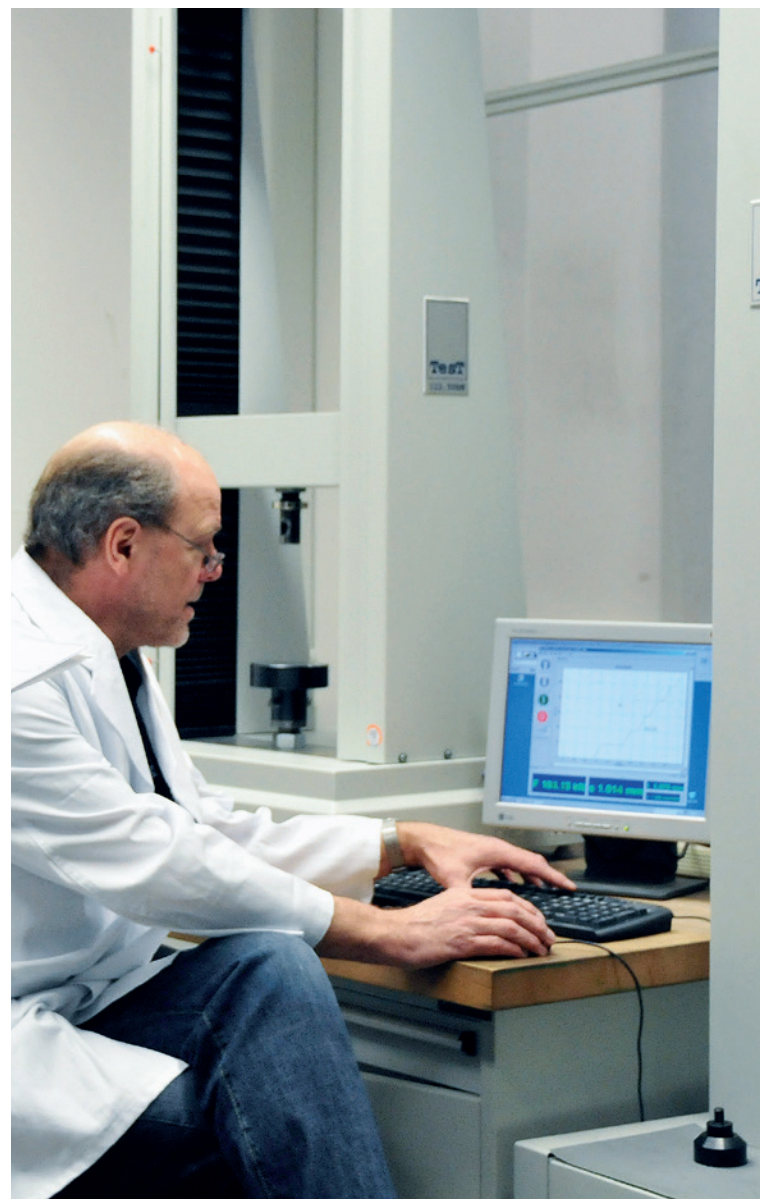

TesT calibration laboratory



## We offer

- Universal testing machines
- Torsion testing machines
- Coefficient of friction testing machines
- Vibration testing machines
- Calibration machines  
(direct loading with masses and electromechanical machines)
- Force and torque sensors
- Force gauges and test frames
- Weighing technology
- DAkkS-Calibration laboratory

Our modular system, modern measurement and control electronics and flexible software provide extensive options for configuring suitable testing machines. Contact us and tell us about your testing task. We will be happy to make our contribution to your future-oriented testing machine.

Subject to technical changes

**WE CARE FOR QUALITY**

TesT GmbH ■ Schützenstraße 102 ■ 42659 Solingen ■ Germany  
test@test-gmbh.com ■ +49 211 209903-0

TesT AG ■ Bösch 63 ■ 6331 Hünenberg ■ Switzerland  
test@test-ag.ch ■ +41 41 785 60 10

P\_Fasteners\_TesT-GmbH  
01.00\_2024-07-18\_EN